



Board of Adjustment

**Staff Report
BOA-23855**

Hearing Date: February 25, 2025
Prepared by: Erin Roark
eroark@cityoftulsa.org
918-596-7618

Owner and Applicant Information

Applicant: MP Advocates
Property Owner: HBSY Properties, LLC

Property Location

5521 North Garrison Avenue East
Tract Size: ±0.17 acres

Location within the City of Tulsa

(shown with City Council districts)

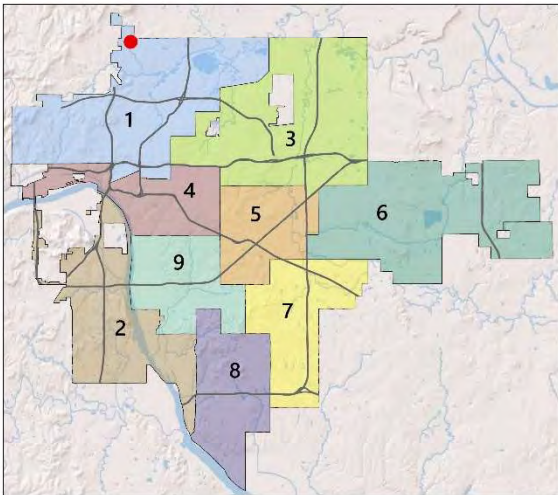

Elected Representatives

City Council: District 1, Vanessa Hall-Harper
County Commission: District 1, Stan Sallee

Public Notice Required

Newspaper Notice – min. 10 days in advance
Mailed Notice to 300’ radius – min. 10 days in advance
Posted Sign – min. 10 days in advance

Request Summary

Special Exception to permit a duplex in the RS-3 district (Section 5.020, Table 5-2, Table 5-2.5); Variance to reduce the required 2,500 square feet of open space per unit for a duplex in the RS-3 district (Section 5.030, Table 5-3)

Zoning

Zoning District: RS-3
Zoning Overlays: N/A

Comprehensive Plan Considerations

Land Use

Land Use Plan: Neighborhood
Small Area Plans: N/A
Development Era: Early Automobile Era

Transportation

Major Street & Highway Plan: Secondary Arterial
planitulsa Street Type: N/A
Transit: Regular Route
Existing Bike/Ped Facilities: N/A
Planned Bike/Ped Facilities: Sidewalks

Environment

Flood Area: N/A
Tree Canopy Coverage: 10-19%
Parks & Open Space: N/A

Staff Analysis

The applicant is requesting a special exception to permit a duplex in the RS-3 district (Section 5.020, Table 5-2, Table 5-2.5) and a variance to reduce the required 2,500 square feet of open space per unit for a duplex in the RS-3 district (Section 5.030, Table 5-3). As proposed, the lot would have a total open space of 4,629 square feet or 2,314.5 square feet per unit, which is 185.5 square feet less than the required 2,500 square feet per unit.

Section 5.020 Use Regulations

Principal uses are allowed in R districts in accordance with [Table 5-2](#).

Table 5-2: R District Use Regulations

USE CATEGORY Subcategory Specific use	RE	RS-					RD	RT	RM-				RMH	Supplemental Regulations
		1	2	3	4	5			0	1	2	3		
RESIDENTIAL														
Household Living (if in allowed building type identified in Table 5-2.5)														
Single household	P	P	P	P	P	P	P	P	P	P	P	P	P	
Two households on single lot	-	-	-	S	S	S	P	P	P	P	P	P	-	
Three or more households on single lot	-	-	-	-	-	S	S	P	P	P	P	P	-	

Table 5-2.5: R District Building Type Regulations for Household Living

USE CATEGORY Subcategory Specific Uses Building Type	RE	RS-					RD	RT	RM-				RMH	Supplemental Regulations
		1	2	3	4	5			0	1	2	3		
RESIDENTIAL														
Household Living														
Single household														
Detached house	P	P	P	P	P	P	P	P	P	P	P	P	S	
Patio House	-	-	-	P	P	P	P	P	P	P	P	P	-	Section 40.290
Townhouse														
2-unit townhouse	-	-	-	S	S	P	P	P	P	P	P	P	-	Section 40.390
3+-unit townhouse	-	-	-	-	-	-	-	P	P	P	P	P	-	Section 40.390
Manufactured housing unit	S	S	S	S	S	S	S	S	S	S	S	S	P	Section 40.210
Manufactured housing subdivision	-	-	-	-	-	-	-	-	-	-	-	-	P	Section 40.220
Mobile home	-	-	-	-	-	-	-	-	-	-	-	-	P	Section 40.240
Mixed-use building	-	-	-	-	-	-	-	-	-	S	S	S	-	
Vertical mixed-use building	-	-	-	-	-	-	-	-	-	S	S	S	-	
Two households on single lot														
Duplex	-	-	-	S	S	S	P	P	P	P	P	P	-	

Section 5.030 Lot and Building Regulations

Table 5-3: R District Lot and Building Regulations

Regulations	RE	RS-1	RS-2	RS-3	RS-4	RS-5	RD	RT	RM-0	RM-1	RM-2	RM-3	RMH
Minimum Lot Area (sq. ft.)													
Detached house	22,500	13,500	9,000	6,900	5,500	3,300	5,500	5,500	5,500	5,500	5,500	5,500	5,500
Patio house	-	-	-	6,900	5,500	3,300	5,500	5,500	5,500	5,500	5,500	5,500	-
Townhouse	-	-	-	4,500	4,500	2,200	2,750	1,600	1,600	1,600	1,600	1,600	-
Cottage house development	-	-	-	-	-	10,000	10,000	10,000	10,000	10,000	10,000	10,000	-
Duplex	-	-	-	6,900	5,500	3,300	5,500	5,500	5,500	5,500	5,500	5,500	-
Multi-unit house	-	-	-	-	-	3,300	6,900	5,500	5,500	5,500	5,500	5,500	-
Apartment/Condo	-	-	-	-	-	-	-	-	10,000	10,000	6,000	24,000	-
Mobile home park	-	-	-	-	-	-	-	-	-	-	-	-	[1]
Other allowed buildings/uses													
Permitted by right	22,500	13,500	9,000	6,900	5,500	5,500	5,500	5,500	5,500	5,500	5,500	5,500	5,500
Special exceptions	22,500	13,500	12,000	12,000	12,000	12,000	12,000	12,000	12,000	12,000	12,000	12,000	12,000
Min. Lot Area per Unit (sq. ft.)													
Detached house	22,500	13,500	9,000	6,900	5,500	3,300	5,500	5,500	5,500	5,500	5,500	5,500	-
Patio house	-	-	-	6,900	5,500	3,300	5,500	5,500	5,500	5,500	5,500	5,500	-
Townhouse	-	-	-	4,500	4,500	2,200	2,750	1,600	1,600	1,600	1,600	1,600	-
Cottage house development	-	-	-	-	-	2,500	2,500	2,500	2,500	2,500	2,500	2,500	-
Duplex	-	-	-	3,450	2,750	1,650	2,750	2,750	2,750	2,750	2,750	2,750	-
Multi-unit house	-	-	-	-	-	1,100	1,800	1,800	1,800	1,375	1,100	900	-
Apartment/Condo	-	-	-	-	-	-	-	-	2,900	1,750	1,100	400	-
Other allowed buildings/uses													
Permitted by right	-	-	-	-	-	-	-	-	5,500	5,500	5,500	5,500	5,500
Special exceptions	22,500	13,500	12,000	12,000	12,000	12,000	12,000	12,000	12,000	12,000	12,000	12,000	12,000
Minimum Lot Width (ft.)													
Detached house	150	100	75	60	50	30	50	50	50	50	50	50	-
Patio house	-	-	-	60	50	30	50	50	50	50	50	50	-
Townhouse	-	-	-	30	25	20	25	20	20	20	20	20	-
Cottage house development	-	-	-	-	-	75	75	75	75	75	75	75	-
Duplex	-	-	-	60	50	30	50	50	50	50	50	50	-
Multi-unit house	-	-	-	-	-	30	50	50	50	50	50	50	-
Apartment/Condo	-	-	-	-	-	-	-	-	100	100	50	100	-
Other allowed buildings/uses													
Permitted by right	150	100	75	60	50	50	50	50	50	50	50	50	50
Special exceptions	150	100	100	100	100	100	100	100	100	100	100	100	100
Minimum Street Frontage													
Residential bldgs/uses [2]	30	30	30	30	30	30	30	30	30	30	30	30	30
Min. Building Setbacks (ft.)													
Street [3]													
Arterial or fwy service rd.	35	35	35	35	35	35	35	35	10	10	10	10	35
Other streets	35	35	30	25	20	20	25	10	10	10	10	10	25
Side (interior) [4]	15	5	5	5	5	5	5	5[5]	5[6]	5[6]	5[6]	5[7]	10
Rear [4]	25	25	25	20	20	20	20	20	20	20	10	20	15
Min. Open Sp./Unit (sq. ft.)	12,000	7,000	5,000	4,000[8]	2,500	600	2,000	1,200	1,200	600	200	-	2,500
Max. Building Height (feet)	35	35	35	35	35	35	35	35	35	35	35	-	35

Relevant Case History

- BOA-07028, May 20, 1971; The board of adjustment approved a special exception to permit a day nurse on the subject property.

Comprehensive Plan Considerations

Land Use Plan

The property is designated as Neighborhood. Neighborhoods are mostly residential uses, which includes detached, missing middle, and multi-dwelling unit housing types. Churches, schools, and other low intensity uses that support residents' daily needs are often acceptable, particularly for properties abutting Multiple Use, Local Center, or Regional Center land use areas. Multi-dwelling unit housing that takes access off an arterial is considered Multiple Use, Local Center, or Regional Center. If a multi-dwelling unit housing property takes access from a lower-order street separated from the arterial, then it would be considered Neighborhood.

Surrounding Properties:

<u>Location</u>	<u>Existing Zoning/Overlay</u>	<u>Existing Land Use Designation</u>	<u>Existing Use</u>
North	RS-3	Neighborhood	Residential
East	RS-3	Neighborhood	Residential
South	RS-3	Neighborhood	Residential
West	RS-3	Neighborhood	Residential

Small Area Plans

The subject property is not within a small area plan.

Development Era

The subject property is in an area developed during the Early Automobile Era (1930s-50s), which retained a high degree of connectivity from neighborhood streets to the arterial network, with mostly commercial, office, industrial, and other active uses along major streets and a mix of housing options and neighborhood-based uses like schools, churches, and libraries in the interior sections. Priorities in these areas include walkability, bikeability, access to public transit, historic preservation, housing type variety, mixed-use development, commercial revitalization, compatibility of scale for neighborhood development, and transitions between commercial corridors and residential areas.

Transportation

Major Street & Highway Plan: East 56th Street North runs parallel to the north side of the subject property and is classified as a Secondary Arterial, which has a planned minimum right-of-way width of 100 feet.

Comprehensive Plan Street Designation: N/A

Transit: Regular Route 110 runs along East 56th Street North.

Existing Bike/Ped Facilities: N/A

Planned Bike/Ped Facilities: Sidewalks are recommended along street frontages.

Arterial Traffic per Lane: East 56th Street North has an average annual daily traffic (AADT) of 1,779 vehicles per lane.

Environmental Considerations

Flood Area: N/A

Tree Canopy Coverage: Tree canopy on the subject property is 16%. Preserving the limited existing canopy should be encouraged, as well as measures to increase the canopy through landscaping. Street-lining trees in particular should be encouraged to spread the benefit of the tree canopy to the pedestrian realm.

Parks & Open Space: N/A

Sample Motion

Special Exception

I move to approve or deny a special exception to permit a duplex in the RS-3 district (Section 5.020, Table 5-2, Table 5-2.5),

- per the conceptual plan(s) shown on page(s) _____ of the agenda packet.
- subject to the following conditions (including time limitation, if any): _____.

The Board finds that the requested Special Exception will be in harmony with the spirit and intent of the Code and will not be injurious to the neighborhood or otherwise detrimental to the public welfare.

Variance

I move to approve or deny a variance to reduce the required open space per unit for a duplex in the RS-3 district (Section 5.030, Table 5-3) from 2,500 square feet per unit to 2,314.5 square feet per unit,

- per the conceptual plan(s) shown on page(s) _____ of the agenda packet.
- subject to the following conditions (including time limitation, if any): _____.

The board finds the hardship to be _____.

In granting the Variance, the Board finds that the following facts, favorable to the property owner, have been established:

- That the physical surroundings, shape, or topographical conditions of the subject property would result in unnecessary hardships or practical difficulties for the property owner, as distinguished from a mere inconvenience, if the strict letter of the regulations were carried out;
- That literal enforcement of the subject zoning code provision is not necessary to achieve the provision’s intended purpose;
- That the conditions leading to the need of the requested variance are unique to the subject property and not applicable, generally, to other property within the same zoning classification;
- That the alleged practical difficulty or unnecessary hardship was not created or self-imposed by the current property owner;
- That the variance to be granted is the minimum variance that will afford relief;
- That the variance to be granted will not alter the essential character of the neighborhood in which the subject property is located, nor substantially or permanently impair use or development of adjacent property; and
- That the variance to be granted will not cause substantial detriment to the public good or impair the purposes, spirit, and intent of this zoning code or the comprehensive plan.

Property Description

LT 45 BLK 52, VALLEY VIEW ACRES THIRD ADDN, City of Tulsa, Tulsa County, State of Oklahoma

Exhibits

- Case map
- Aerial (small scale)
- Aerial (large scale)
- Tulsa Comprehensive Plan Land Use Map

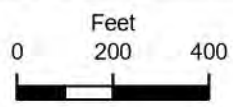
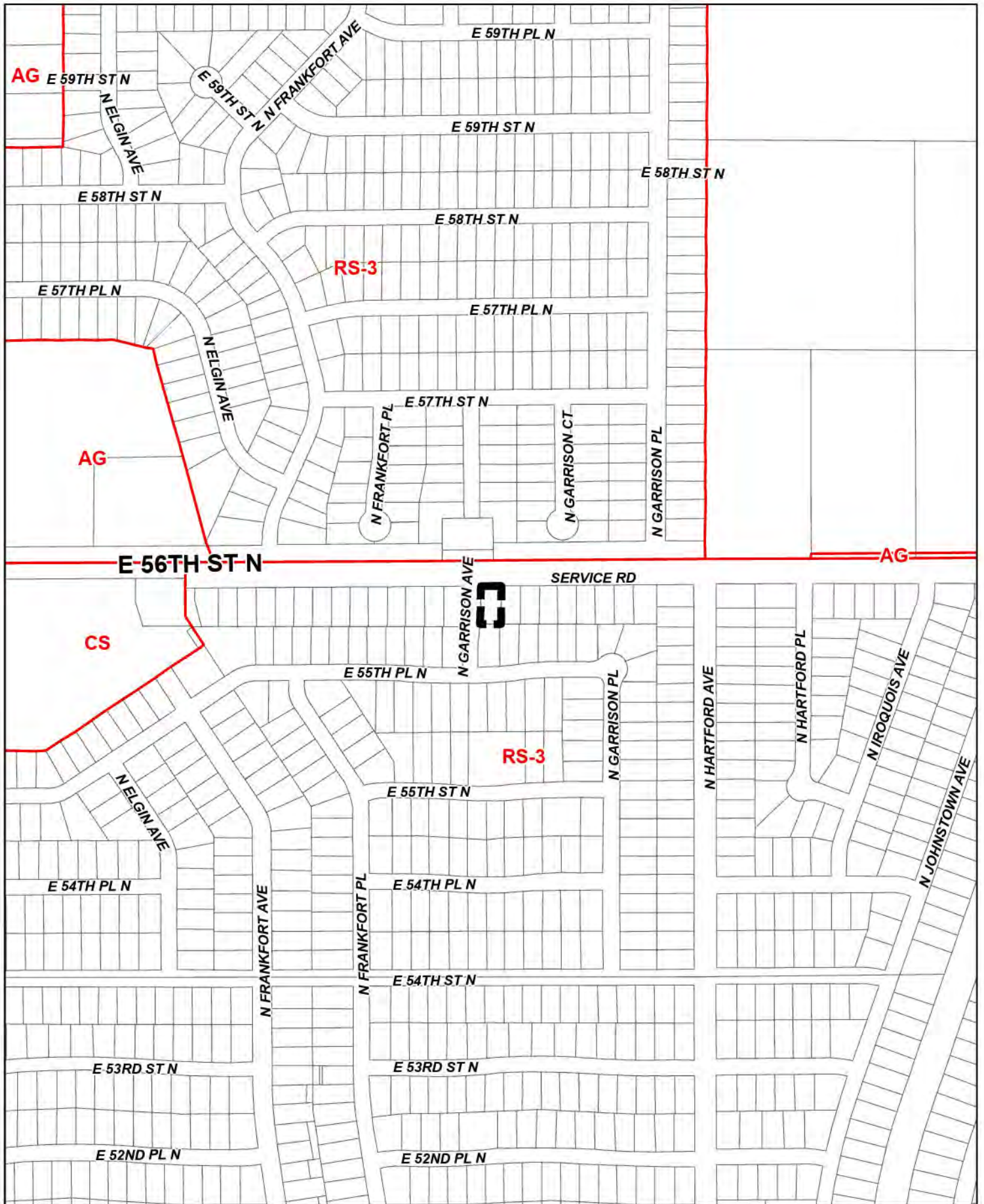

 Subject Tract

BOA-23855

20-12 12



14.6

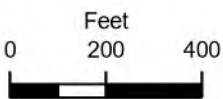
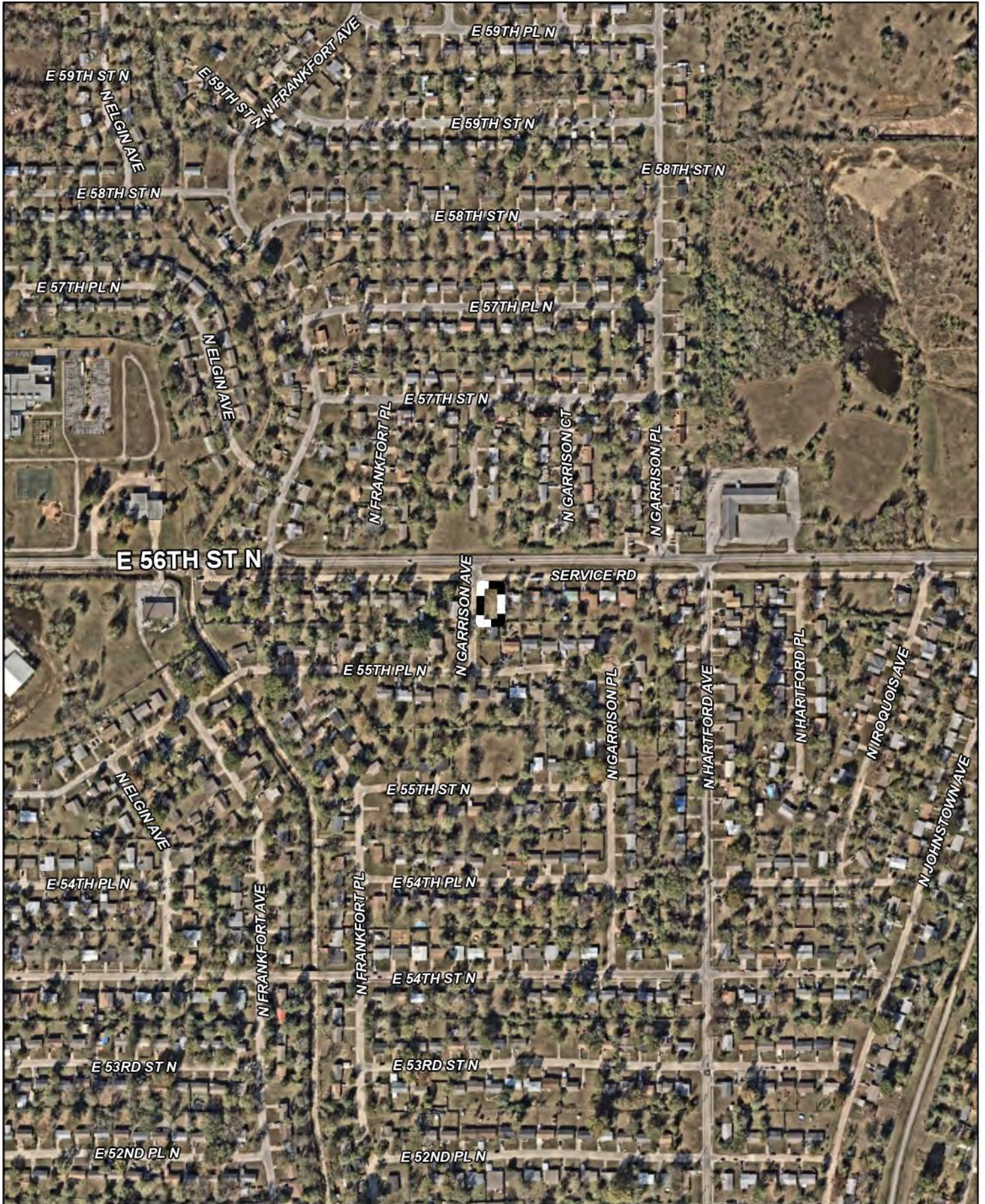

Subject Tract

BOA-23855

20-12 12

Note: Graphic overlays may not precisely align with physical features on the ground.

Aerial Photo Date: 2024



14.7



E 56TH ST N

SERVICE RD

N GARRISON AVE

E 55TH PL N

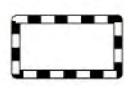
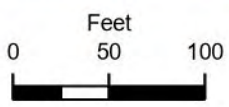

Subject Tract

BOA-23855

20-12 12

Note: Graphic overlays may not precisely align with physical features on the ground.







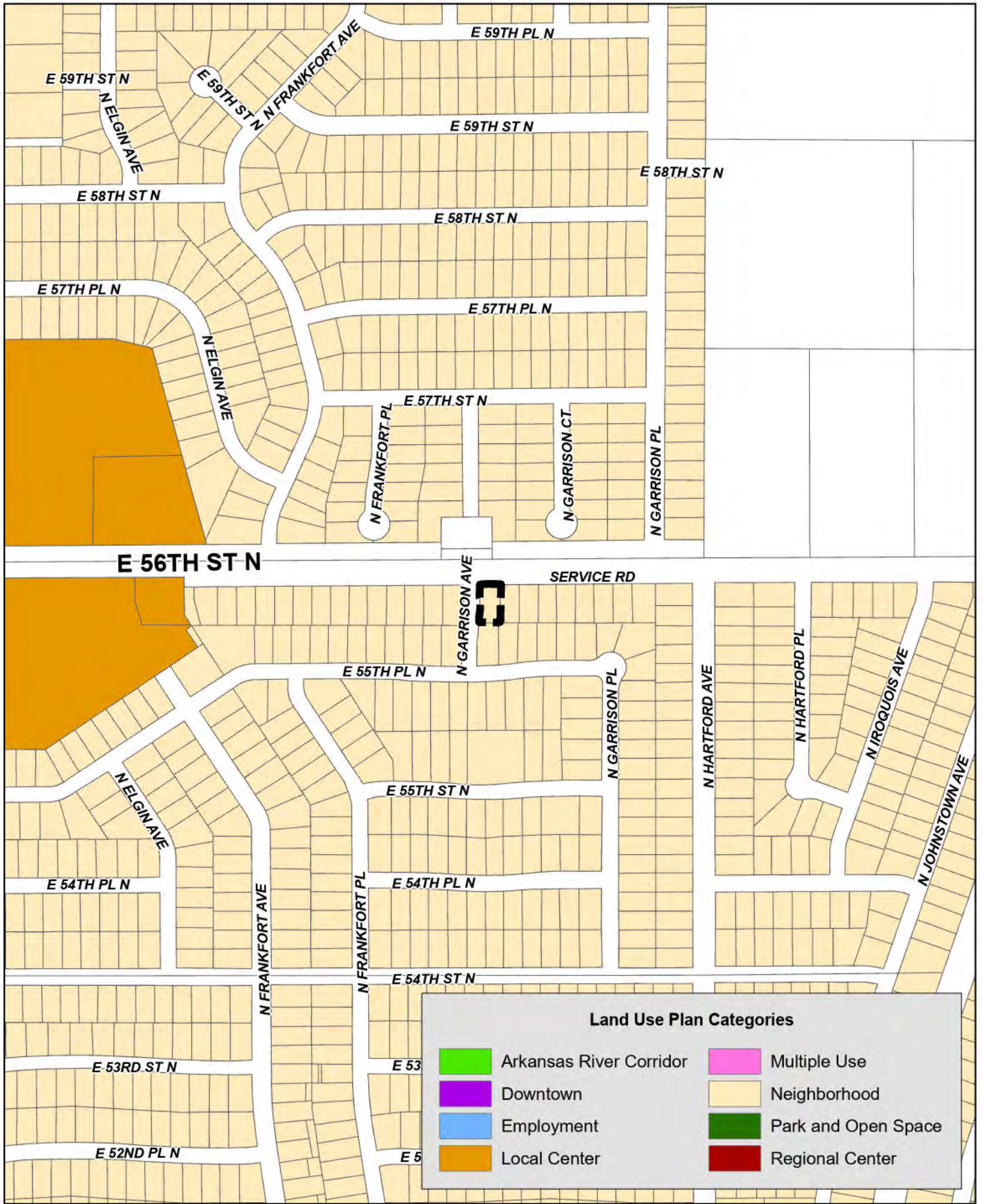

Aerial Photo Date: 2024



14.8



Land Use Plan Categories

	Arkansas River Corridor		Multiple Use
	Downtown		Neighborhood
	Employment		Park and Open Space
	Local Center		Regional Center

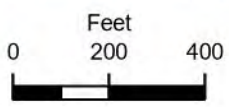

 Subject Tract

BOA-23855

20-12 12



14.9

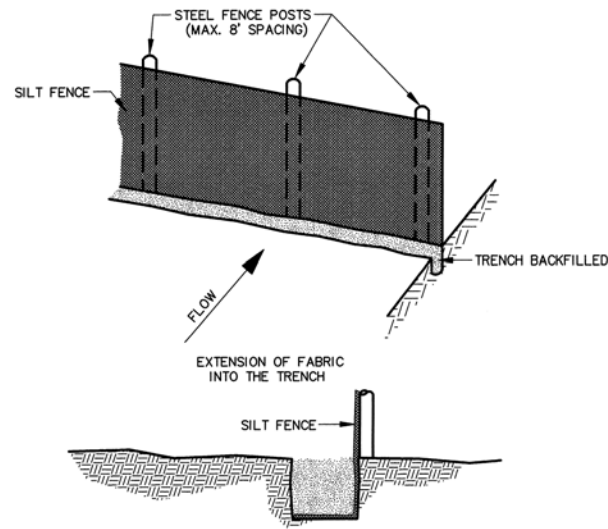

STANDARD SILT FENCE NOTES:

1. STEEL POSTS WHICH SUPPORT THE SILT FENCE SHALL BE INSTALLED ON A SLIGHT ANGLE TOWARD THE ANTICIPATED RUNOFF SOURCE.
2. THE TOE OF THE SILT FENCE SHALL BE TRENCHED IN WITH A SPADE OR MECHANICAL TRENCHER, SO THAT THE DOWNSLOPE FACE OF THE TRENCH IS FLAT AND PERPENDICULAR TO THE LINE OF FLOW.
3. THE TRENCH SHOULD BE A MINIMUM OF 6 INCHES DEEP AND 3-4 INCHES WIDE TO ALLOW FOR THE SILT FENCE TO BE LAID IN THE TRENCH 4" AND BACKFILLED.
4. SILT FENCE SHOULD BE SECURELY FASTENED TO EACH STEEL SUPPORT POST OR TO WOVEN WIRE, WHICH IS IN TURN ATTACHED TO THE STEEL FENCE POSTS.
5. INSPECTION SHALL BE FREQUENT AND REPAIR OR REPLACEMENT SHALL BE MADE PROMPTLY AS NEEDED.
6. SILT FENCE SHALL BE REMOVED WHEN IT HAS SERVED ITS USEFULNESS SO AS NOT TO BLOCK OR IMPEDE STORM FLOW OR DRAINAGE.
7. SEDIMENT TRAPPED BY THIS PRACTICE SHALL BE DISPOSED OF IN AN APPROVED SITE, IN A MANNER THAT WILL NOT CONTRIBUTE TO ADDITIONAL SILTATION.
8. ACCUMULATED SILT SHALL BE REMOVED WHEN IT REACHES A DEPTH OF 6 INCHES AND DISPOSED OF IN AN APPROVED SPOIL SITE OR AS IN NO. 7 ABOVE.

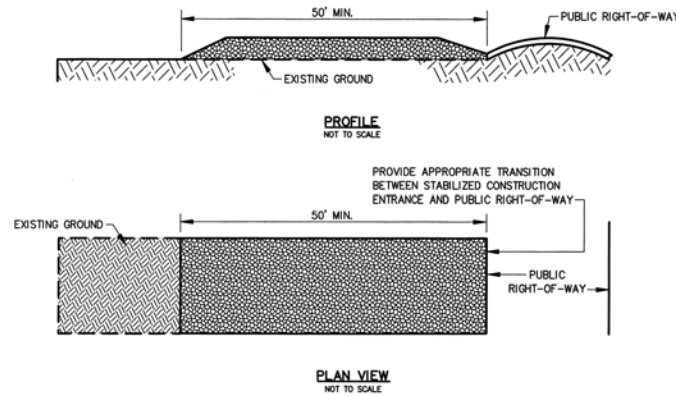

STANDARD CONSTRUCTION ENTRANCE NOTES:

1. STONE SIZE AASHTO DESIGNATION M43, SIZE NO. 2 (2-1/2" TO 1-1/2"). USE CRUSHED STONE.
2. LENGTH - AS EFFECTIVE, BUT NOT LESS THAN 50 FEET.
3. THICKNESS - NOT LESS THAN EIGHT (8) INCHES.
4. WIDTH - NOT LESS THAN FULL WIDTH OF ALL POINTS OF INGRESS OR EGRESS.
5. WASHING - WHEN NECESSARY, WHEELS SHALL BE CLEANED TO REMOVE SEDIMENT PRIOR TO ENTRANCE ONTO PUBLIC RIGHT-OF-WAY. WHEN WASHING IS REQUIRED, IT SHALL BE DONE ON AN AREA STABILIZED WITH CRUSHED STONE WHICH DRAINS INTO AN APPROVED SEDIMENT TRAP OR SEDIMENT BASIN.
6. ALL SEDIMENT SHALL BE PREVENTED FROM ENTERING ANY STORM DRAIN, DITCH, OR WATERCOURSE THROUGH USE OF SANDBAGS, GRAVEL, BOARDS, OR OTHER APPROVED METHODS.
7. MAINTENANCE - THE ENTRANCE SHALL BE MAINTAINED IN A CONDITION WHICH WILL PREVENT TRACKING OR FLOWING OF SEDIMENT ONTO PUBLIC RIGHT-OF-WAYS. THIS MAY REQUIRE PERIODIC TOP DRESSING WITH ADDITIONAL STONE AS CONDITIONS DEMAND AND REPAIR AND/OR CLEANOUT OF ANY MEASURES USED TO TRAP SEDIMENT. ALL SEDIMENT SPILLED, DROPPED, WASHED, OR TRACKED ONTO PUBLIC RIGHT-OF-WAYS MUST BE REMOVED IMMEDIATELY BY THE CONTRACTOR.

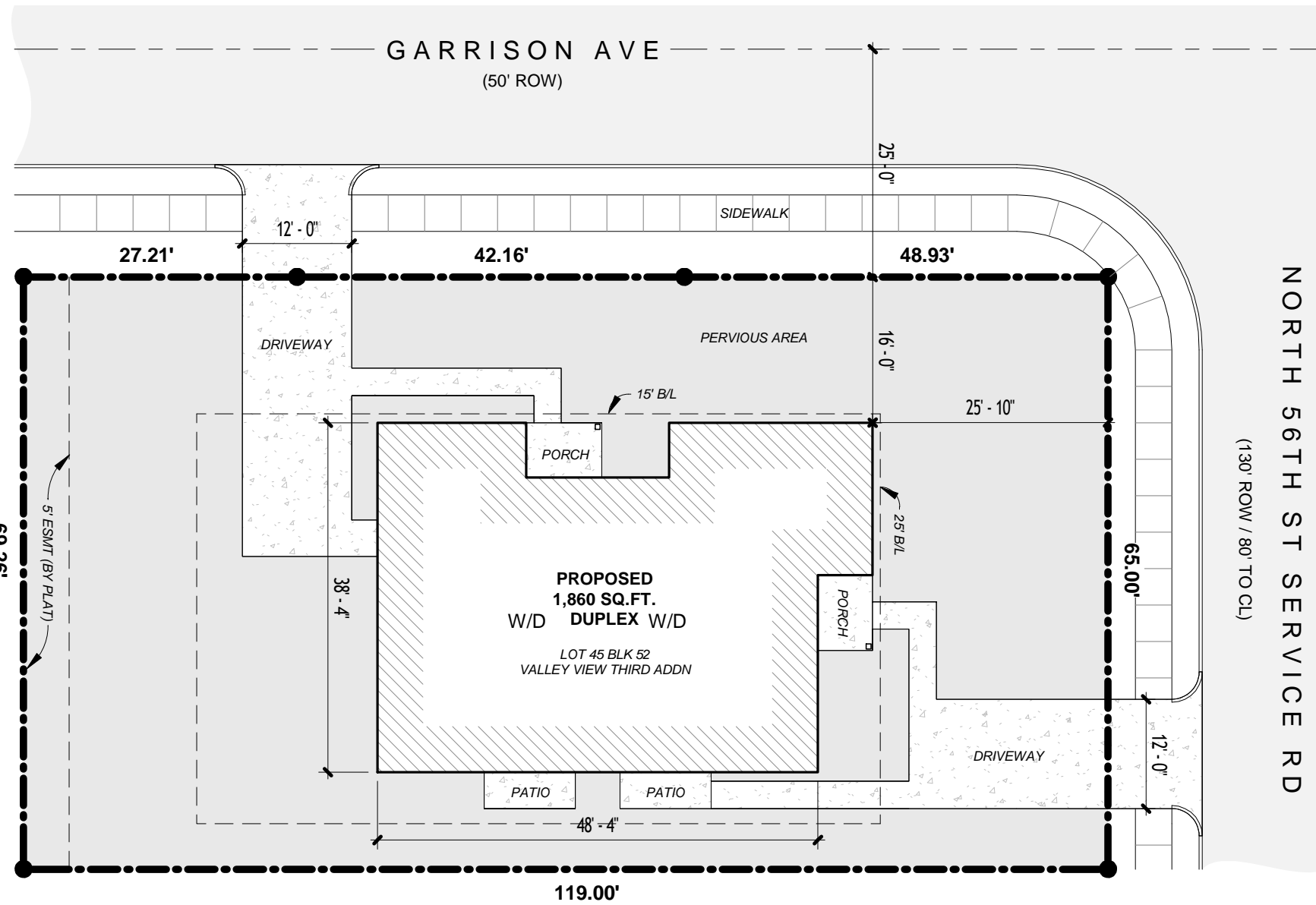

SITE METRICS	
ZONING DESIGNATION:	RS-3
LOT AREA (FROM ASSESSOR):	7,540 SQ.FT.
BUILDING AREA:	1,860 SQ.FT.
PERVIOUS COVER:	2,911 SQ.FT.
OPEN SPACE:	4,629 SQ.FT.

ALL SITE DEPICTIONS AND METRICS PROVIDED HEREIN ARE APPROXIMATIONS ONLY. BUILDER SHALL OBTAIN A PROPERTY SURVEY FROM A LICENSED SURVEYOR PRIOR TO CONSTRUCTION.

LOT 46 BLK 52



* SUBJECT PROPERTY IS NOT WITHIN FEMA FLOODPLAIN NOR WITHIN 50' OF CITY OF TULSA REGULATORY FLOODPLAIN.

1 PROPOSED PLOT PLAN

SCALE: 1/16" = 1'-0"



M+P ADVOCATES
 MAPPING | PLANNING | DESIGN
 T: 918.695.7215
 E: MPLUSPNET@GMAIL.COM

PREPARED FOR:
HBSY PROPERTIES LLC

PROJECT ID: **P-2430**

5521 N GARRISON AVE

NEW CONSTRUCTION PERMIT SET

SITE ADDRESS: 5521 N GARRISON AVE, TULSA, OK 74126
 LEGAL DESCRIPTION: LOT 45, BLK 52 VALLEY VIEW ACRES THIRD ADDN

PUBLISH DATE: **2025-01-23**

THIS SHEET SET AND THE DRAWINGS CONTAINED HEREIN SHALL NOT BE MODIFIED OR REPRODUCED WITHOUT THE EXPLICIT, WRITTEN CONSENT OF M+P ADVOCATES.

SHEET:
PROPOSED SITE PLAN

SP1

14.10